



FULL MANUAL

<https://www.bft-automation.com/qrcodemanual/D814283>

THALIA BT A80/A160



D814375 0ADAO_08_28-10-25

IT	LINGUA ORIGINALE
EN	TRANSLATED VERSION
FR	VERSION TRADUITE
DE	ÜBERSETZTE VERSION
ES	VERSION TRADUCIDA
NL	VERTAALDE VERSIE
PT	VERSÃO TRADUZIDA
EL	ΜΕΤΑΦΡΑΣΜΕΝΗ ΕΚΔΟΣΗ
PL	WERSJA TŁUMACZONA
RU	ПЕРЕВОДНАЯ ВЕРСИЯ
CS	PŘEKLOŽENÁ VERZE
TR	ÇEVİRİLEN VERSİYON
HR	PREVEDENA VERZIJA
RO	VERSIUNE TRADUS

النسخة المترجمة AR

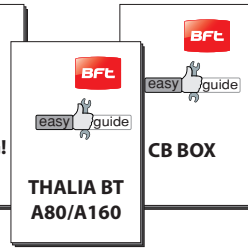
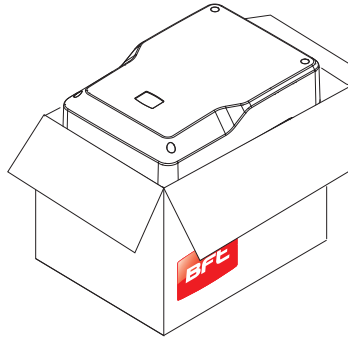

DUO

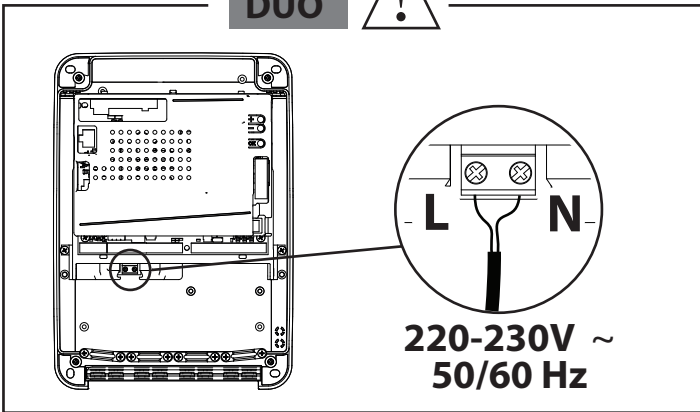

220-230V ~
50/60 Hz

FLAT

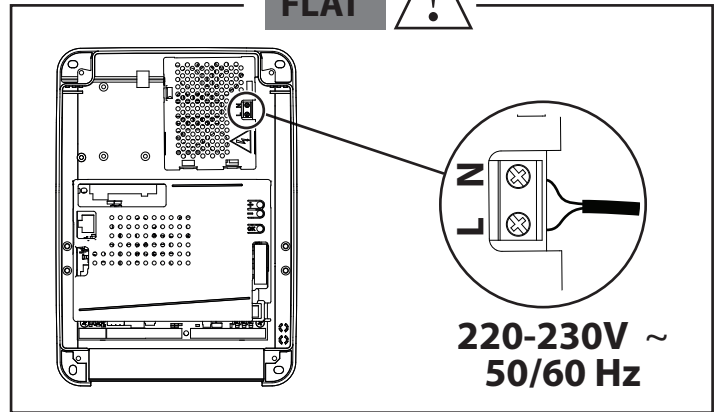

220-230V ~
50/60 Hz

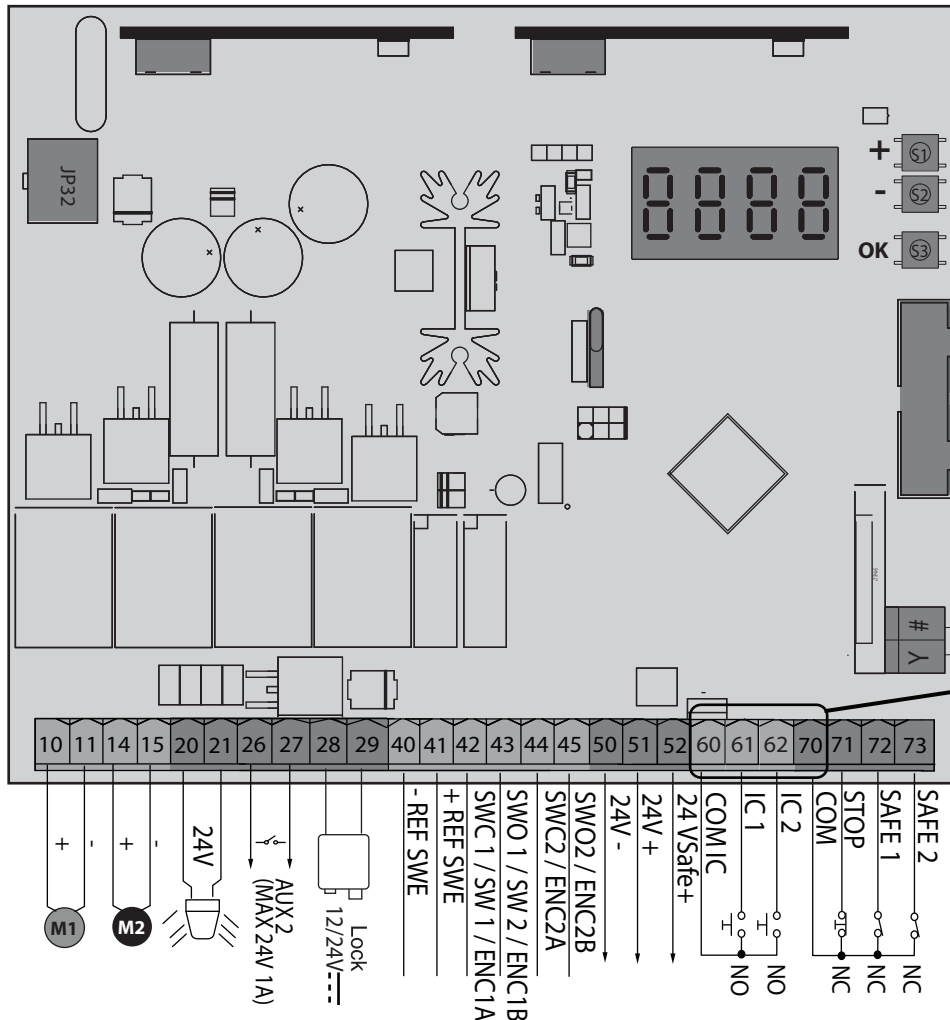

	THALIA BT A80	THALIA BT A160
	220-230 V 50/60 Hz	
P stand-by	0,48 W	
Pmax	200 W	400 W
	433,92 MHz	
IP	DUO	DUO
	45	45
	-20°C / +60°C	-20°C / +55°C

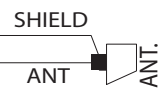

07 COM

09 COM IC

COM ≠ COM IC

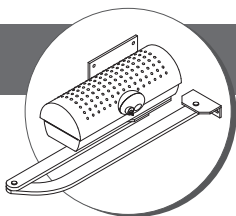

IGEA BT

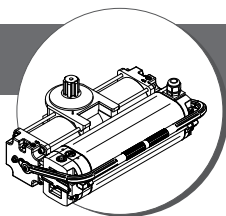
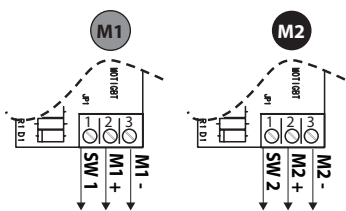
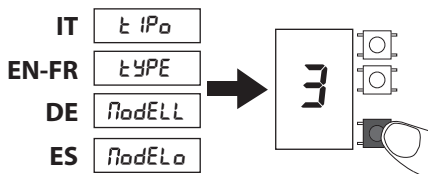

SUB BT

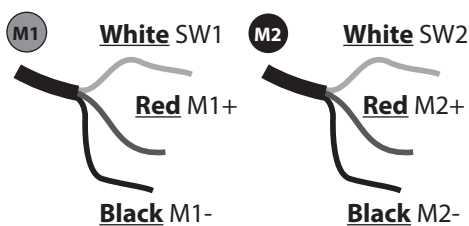
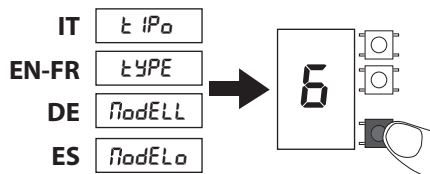

White Bianco - Blanc - Weiß - Blanco - Wit - Brancov - Λευκή - biały - белый - bílá - Ak - Bijela - Alb - أبيض

Red Rosso - Roug - Rot - Rojo - Rood - Vermelho - κόκκινο - czerwony - красный - červený - kırmızı - Crvena - Roşu - أحمر

Black Nero - Noir - Nero - Negro - Zwart - Preto - μαύρο - czarny - черный - černý - siyah - Crno - Negro - أسود

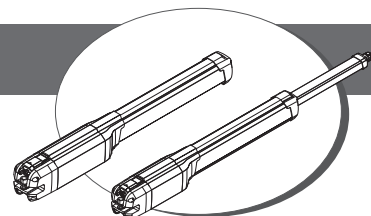
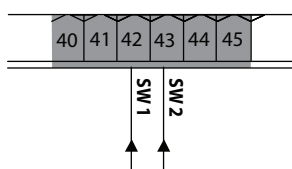
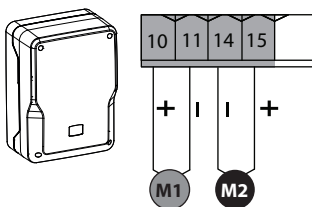

**PHOBOS BT A - PHOBOS BT B
KUSTOS BT A - KUSTOS BT B**

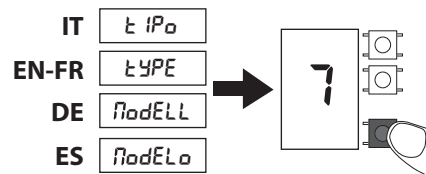

PHOBOS VELOCE BT B35

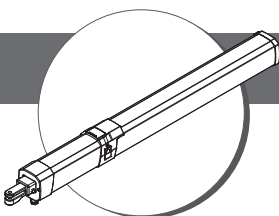
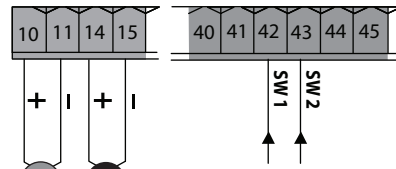
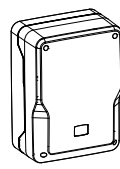
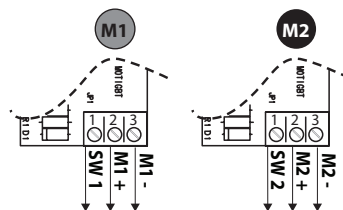
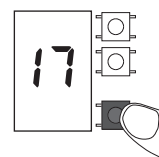

GIUNO ULTRA

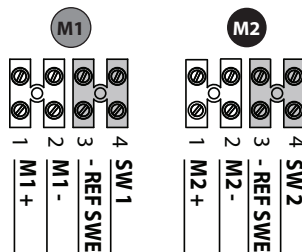
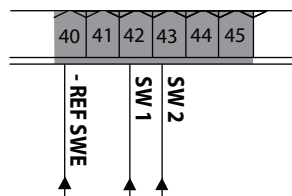
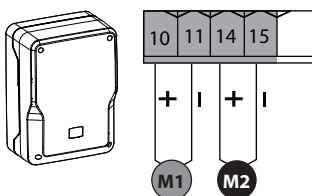
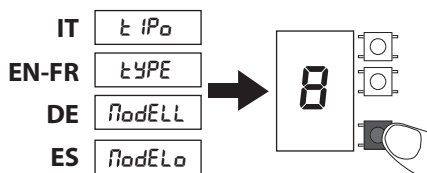

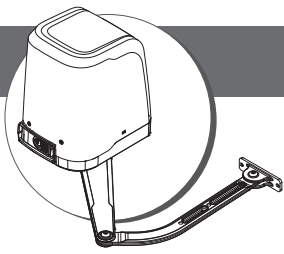

VIRGO SMART BT A SLAVE

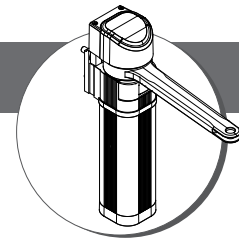
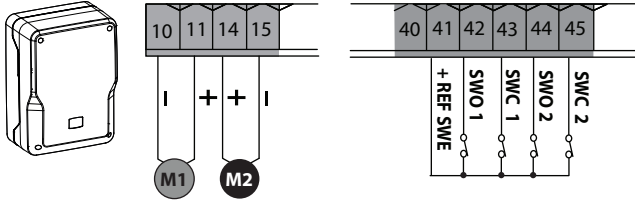
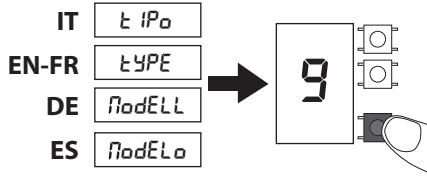

E5 BT A 18

E5 BT A 12

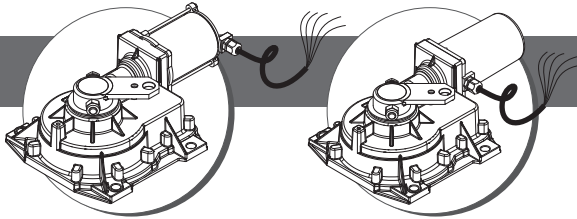
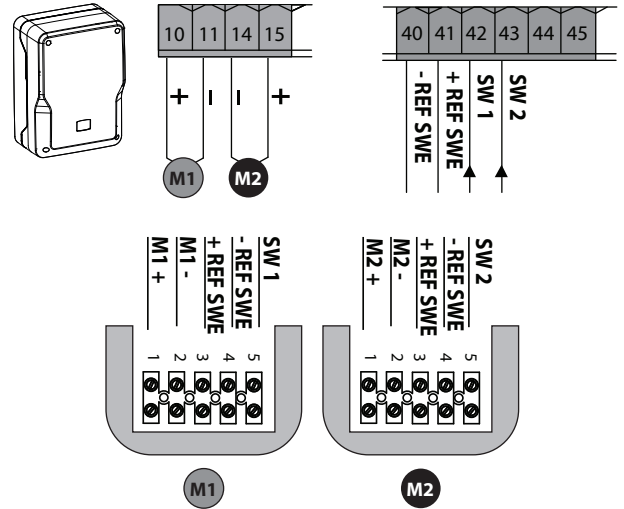
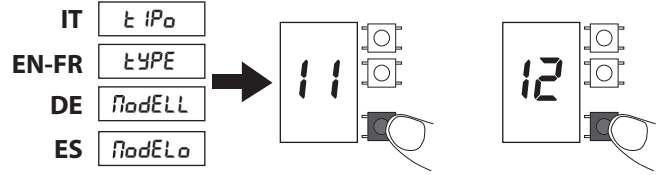

ELI BT A40

ELI BT A35V

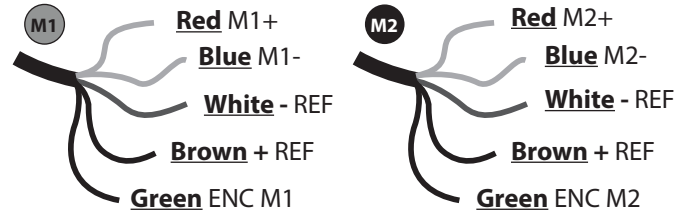
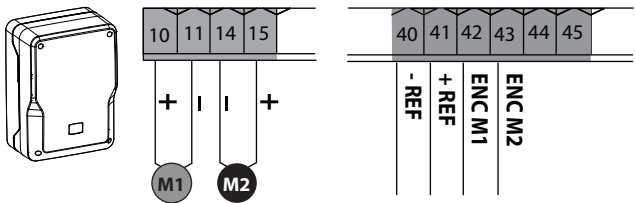
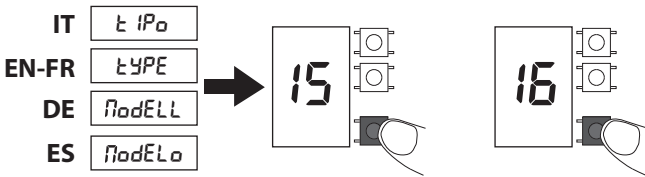

Red: Rosso - Roug - Rot - Rojo - Rood - Vermelho - κόκκινο - czerwony - красный - červený - kırmızı - Crvena - Roşu - أحمر

Bleu: Blu - Bleu - Blau Azul - Blauw - Azul Μπλε - niebieski - синий - mo-dro - mavi - Plava - alabastru - أزرق

White: Bianco - Blanc - Weiß - Blanco - Wit - Brancov - Λευκή - biały - белый - bílá - Ak - Bijela - Alb - أبيض

Brown: Marrone - Marron Braun - Maron - bruin - Castanho - καφέ - brązowy - коричневый - hnědý - kahverengi - Smeđa - Marro - بني

Green: Verde - Vert - Grün Verde - Groen - Verde Πράσινη - Gre-enЗеленый - Zelená - Yeşil - Zelena - Verde - أخضر

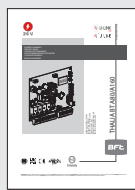
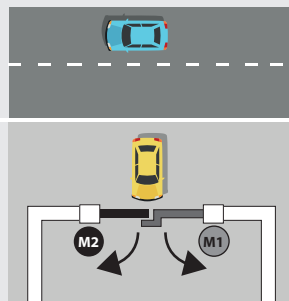

<https://www.bft-automation.com/qrcodemanual/D814283>

COME PROGRAMMARE LA SCHEDA - HOW TO PROGRAM THE BOARD
 COMMENT PROGRAMMER LA CARTE - PROGRAMMIERUNG DER REGISTERKARTE
 CÓMO PROGRAMAR LA TARJETA - HOE DE KAART TE PROGRAMMEREN
 COMO PROGRAMAR A PLACA - ΤΡΟΠΟΣ ΠΡΟΓΡΑΜΜΑΤΙΣΜΟΥ ΤΗΣ ΠΛΑΚΕΤΑΣ
 JAK ZAPROGRAMOWAĆ KARTĘ - ПРОГРАММИРОВАНИЕ ПЛАТЫ
 JAK NAPROGRAMOVAT KARTU - KARTIN NASIL PROGRAMLANACAĞI
 ΚΑΚΟ PROGRAMIRATI PLOČU - CUM SE PROGRAMEAZĂ PLACA DE CIRCUITE -

كيفية برمجة المجلس

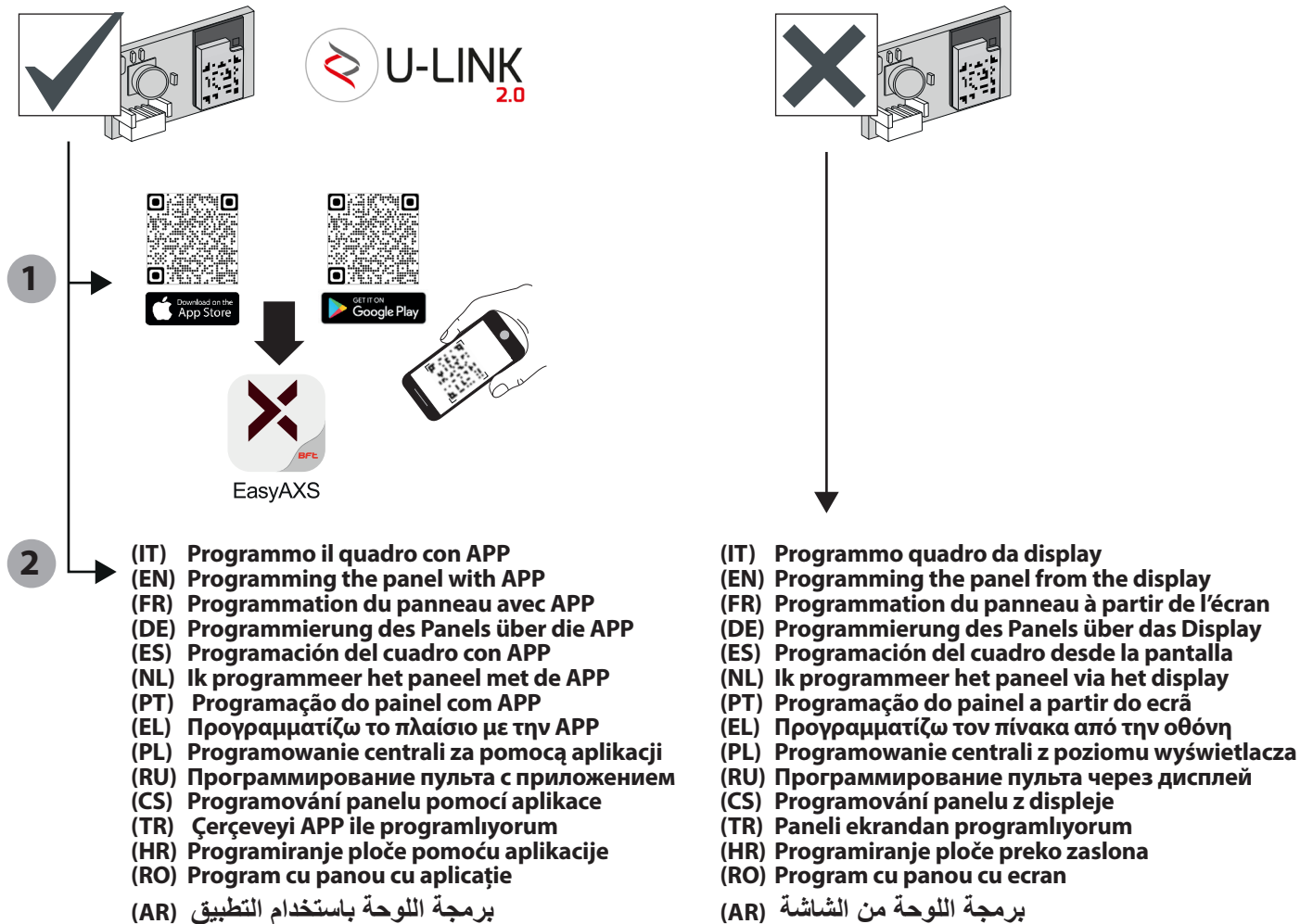

AZIENDA CON
 SISTEMA DI GESTIONE
 CERTIFICATO DA DNV GL
 = ISO 9001 =
 = ISO 14001 =



U-Security



24 V



8 027908 796486 >